

ADDENDUM NUMBER 01 TO THE BID DOCUMENTS

To all general contract bidders of record on the Bid Proposal:

**BID DOCUMENT: #I26-35610
Building 18 Roof Replacement #I26
College of Marin – Indian Valley**

Addendum Date: August 25, 2017

- A. This addendum shall be considered part of the bid documents for the above mentioned project as though it had been issued at the same time and shall be incorporated integrally therewith. Where provisions of the following supplementary data differ from those of the original bid documents, this Addendum shall govern and take precedence.
- B. Bidders are hereby notified that they shall make any necessary adjustments in their estimates as a result of this Addendum. It will be construed that each bidder's proposal is submitted with full knowledge of all modifications and supplemental data specified herein.

The bid documents are modified and clarified, as follows:

Item #1: Document NOTICE INVITING BIDS, 15 Owner-Controlled or Wrap-Up Insurance Program: CHANGE The District has elected to provide an Owner-Controlled or Wrap-Up Insurance Program (OCIP). TO The District has elected to NOT provide an Owner-Controlled or Wrap-Up Insurance Program (OCIP).

Item #2: Document INSTRUCTIONS TO BIDDERS, 12 Owner-Controlled or Wrap-Up Insurance Program (OCIP): CHANGE The District has elected to provide an Owner-Controlled or Wrap-Up Insurance Program (OCIP). TO The District has elected to NOT provide an Owner-Controlled or Wrap-Up Insurance Program (OCIP).

Item #3: Document BID PROPOSAL FORM, Owner Allowance: Unforeseen Repair of damaged roof decking CHANGE (\$20,000) TO (\$5,000).

Item #4: Document BID PROPOSAL FORM: CHANGE Bidder specifically acknowledges and understands that if it is awarded the Contract, that it and its subcontractors shall participate in and comply with the Owner-Controlled or Wrap-Up Insurance Program (OCIP) TO Bidder specifically acknowledges and understands that if it is awarded the Contract, that it and its subcontractors shall NOT participate in and comply with the Owner-Controlled or Wrap-Up Insurance Program (OCIP).

Item #5: Document AGREEMENT SAMPLE, 8. Insurance and Bonds:

CHANGE Contractor and all Subcontractors under the Contractor shall participate in and comply with the owner-controlled or wrap-up insurance program (OCIP) TO Contractor and all Subcontractors under the Contractor shall NOT participate in and comply with the owner-controlled or wrap-up insurance program (OCIP)

Item #6: Document GENERAL CONDITIONS, 11. Insurance, a.: CHANGE A VIII TO A: VII FOR all occasions.

Item #7: Document GENERAL CONDITIONS, 11. Insurance, b.: CHANGE Contractor and all Subcontractors under the Contractor shall participate in and comply with the owner-controlled or wrap-up insurance program (OCIP) TO Contractor and all Subcontractors under the Contractor shall NOT participate in and comply with the owner-controlled or wrap-up insurance program (OCIP).

Item #8: Document SECTION 07 55 00 - DELETE

Item #9: Document ROOF PLAN and details dated 8/4/2017 DELETE

Item #10: Document ADD AD1 ROOF PLAN and details dated 8/25/2017.

Item #11: Document Indian Valley Campus map showing access and 20 ton limit on bridge added for reference.

Submitted Questions:

Question #1: On the specs its calling out for roof vents, will there be any type of ventilation like ridge vents of some kind?

Answer #1: No vents are to be installed.

Question #2: What's under the existing wood shingles?

Answer #2: Under the wood shakes the assembly is: felt, 1x4 wood battens, aluminum radiant barrier, 2" woodfiber, 3/8" plywood, craft paper, T&G wood deck.

Question #3: On the Specs its calling out for the canopies will it be included?

Answer #3: Canopy not included in scope of work.

End of Addendum #01

To be completed by bidder and submitted with bid.

BID PROPOSAL FORM

Governing Board
Marin Community College District

Dear Members of the Governing Board:

The undersigned, doing business under the name of _____

_____, having carefully examined the location of the proposed work, the local conditions of the place where the work is to be done, the Notice Inviting Bids, the General Conditions, the Instructions to Bidders, the Plans and Specifications, and all other Contract Documents for the proposed **Indian Valley Campus Building 18 Roof Replacement Project #I26-35610**, ("Project"), and having accurately completed the Bidder's Questionnaire, proposes to perform all work and activities in accordance with the Contract Documents, including all of its component parts, and to furnish all required labor, materials, equipment, transportation and services required for the construction of the Project in strict conformity with the Contract Documents, including the Plans and Specifications as follows:

BASE BID:
For the sum of:
_____ Dollars (\$ _____)

Owner Allowance:
Unforeseen repair of damaged roof decking (\$ 5,000)

TOTAL BASE BID:
For the sum of:
_____ Dollar (\$ _____)

The undersigned has checked carefully all the above figures and understands that the District is not responsible for any errors or omissions on the part of the undersigned in making this bid.

ADDENDA:

Receipt of the following addenda is hereby acknowledged:

Addendum # _____ Dated: _____ Addendum # _____ Dated: _____

Documents Accompanying Bid. The Bidder has submitted with this Bid Proposal the following: (a) Bid Security; (b) Subcontractors List; (c) Non-Collusion Declaration; (d) Workers' Compensation, Certification; (e) W9 Request for Taxpayers Identification Number and Certification; (f) Roofing Certification; (g) Prevailing Wage and Related Labor Requirements Certification; and (h) Site Visit Certification. The Bidder acknowledges that if this Bid Proposal and the foregoing documents are not fully in compliance with applicable requirements set forth in the Call for Bids, the Instructions for Bidders and in each of the foregoing documents, the Bid Proposal may be rejected as non-responsive.

Award of Contract. If the Bidder submitting this Bid Proposal is awarded the Contract, the undersigned will execute and deliver to the District the Contract for Labor and Materials in the form attached hereto within five (5) days after notification of award of the Contract. Concurrently with delivery of the executed Agreement to the District, the Bidder awarded the Contract shall deliver to the District: (a) Certificates of Insurance evidencing all insurance coverages required under the Contract Documents; (b) the Performance Bond; (c) the Labor and Material Payment Bond; (d) Sex Offender Registration Act Certification; (e) the Drug-Free Workplace Certificate; (f) Tobacco-Free Environment Certification; and (g) Hazardous Material Certification. Failure of the Bidder awarded the Contract to strictly comply with the preceding may result in the District's rescission of the award of the Contract and/or forfeiture of the Bidder's Bid Security. In such event, the District may, in its sole and exclusive discretion elect to award the Contract to the responsible Bidder submitting the next lowest Bid Proposal, or to reject all Bid Proposals.

Contractor's License. The undersigned Bidder is currently and duly licensed in accordance with the California Contractors License Law, California Business & Professions Code §§7000 et seq., under the following classification(s) B bearing License Number(s) _____, with expiration date(s) of _____. The Bidder certifies that: (a) it is duly licensed, in the necessary class(es), for performing the Work of the Contract Documents; (b) that such license shall be in full force and effect throughout the duration of the performance of the Work under the Contract Documents; and (c) that all Subcontractors providing or performing any portion of the Work shall be so properly licensed to perform or provide such portion of the Work.

Acknowledgment and Confirmation. The undersigned Bidder acknowledges its receipt, review and understanding of the Drawings, the Specifications and other Contract Documents pertaining to the proposed Work. The undersigned Bidder certifies that the Contract Documents are, in its opinion, adequate, feasible and complete for providing, performing and constructing the Work in a sound and suitable manner for the use specified and intended by the Contract Documents. The undersigned Bidder certifies that it has, or has available, all necessary equipment, personnel, materials, facilities and technical and financial ability to complete the Work for the amount bid herein within the Contract Time and in accordance with the Contract Documents.

Bidder specifically acknowledges and understands that if it is awarded the Contract, that it and its subcontractors shall NOT participate in and comply with the Owner-Controlled or Wrap-Up Insurance Program (OCIP).

The Bidder represents that it is competent, knowledgeable and has the special skills with respect to the nature, extent, and inherent conditions of the Work to be performed. Bidder further acknowledges that there are certain peculiar and inherent conditions existent in the construction of the Work that may create, during the Work, unusual or peculiar unsafe conditions hazardous to persons and property.

Bidder expressly acknowledges that it is aware of such peculiar risks and that it has the skills and experience to foresee and to adopt protective measures to adequately and safely perform the Work with respect to such hazards.

Bidder expressly acknowledges that it is aware that if a false claim is knowingly submitted (as the terms "claim" and "knowingly" are defined in the California False Claims Act, Cal. Gov. Code, §12650 et seq.), the District will be entitled to civil remedies set forth in the California False Claim Act. It may also be considered fraud and the Contractor may be subject to criminal prosecution.

The undersigned Bidder certifies that it is, at the time of bidding, and shall be throughout the period of the contract, licensed by the State of California to do the type of work required under the terms of the Contract Documents and registered as a public works contractor with the Department of Industrial Relations. Bidder further certifies that it is regularly engaged in the general class and type of work called for in the Contract Documents.

Furthermore, Bidder hereby certifies to the District that all representations, certifications, and statements made by Bidder, as set forth in this bid form, are true and correct and are made under penalty of perjury.

Respectfully Submitted,

Company: _____

Address: _____

By: _____

(Please Print Or Type)

Signature: _____

Title: _____

Date: _____

Taxpayer's Identification No. of Bidder _____

Phone: _____

Contractor's License No: _____ Expiration Date _____

END OF DOCUMENT

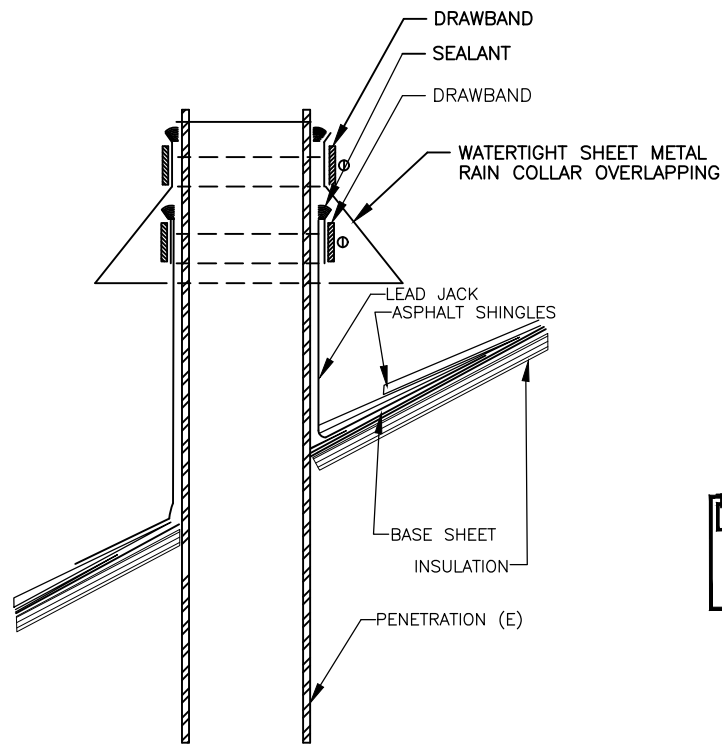

A
3 ROUND PENETRATION
ARCH. REF.: N.T.S

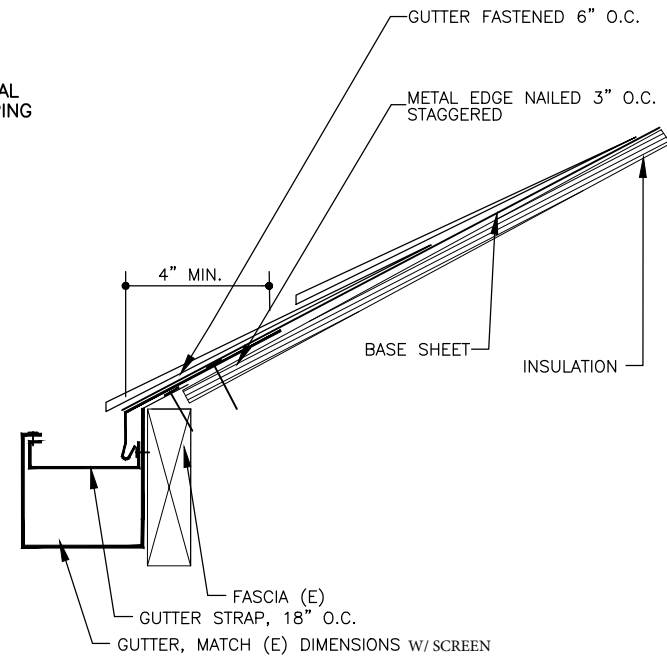

B
3 SHINGLE ROOF EDGE WITH GUTTER
ARCH. REF.: N.T.S

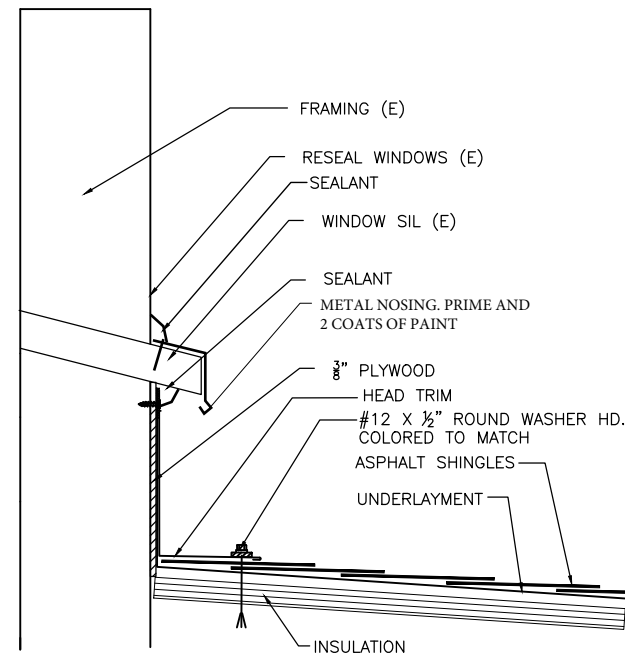

C
3 SHINGLE HEAD @ WINDOW
ARCH. REF.: N.T.S

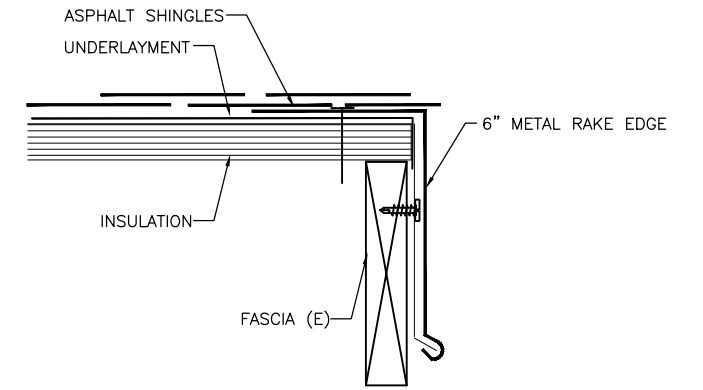

D
3 SHINGLE RAKE
ARCH. REF.: N.T.S

SHEET NOTES:

- 1 Remove all wood shake roofing, asbestos felt, wood batts, aluminum radiant barrier and insulation (2" wood fiber) to wood deck.
- 2 Install 2" base layer of insulation, nail base, underlayment, asphalt shingles and sheet metal.
- 3 Trellis and covered walkway N.I.C.

GENERAL NOTES:

Verify all dimensions in field.
 Not all penetrations shown.
 All items not shown as existing (E) are to be new.

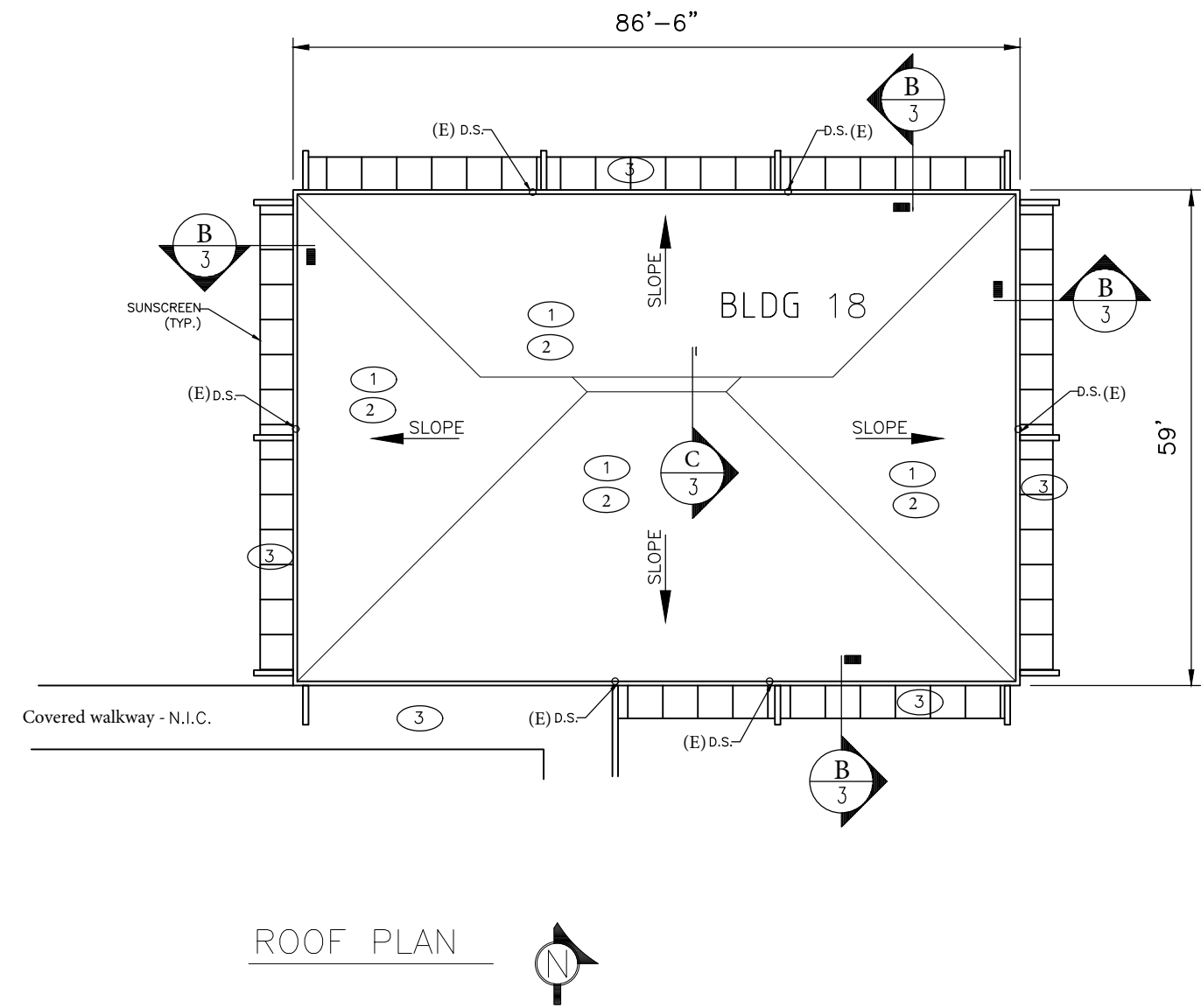

ROOF PLAN

SYMBOL LEGEND	
⊙	EXHAUST FAN
○	DOWN SPOUT
⊕	ROOF DRAIN

AD1

REVISION: AD1	INDIAN VALLEY COLLEGE - BLDG 18		
	MORRO, CA		
SHEET: 1	ARCHITECT:	AGENT:	CHK BY: MG
	DATE: 8/25/2017	JOB NUMBER:	DWG BY: GCK
OF 2	CUSTOMER:		

Authorized personnel only in construction zones.
Must wear hard hat and safety vest at all times.

College of Marin is a smoke-free environment. Smoking is permitted in designated areas only.

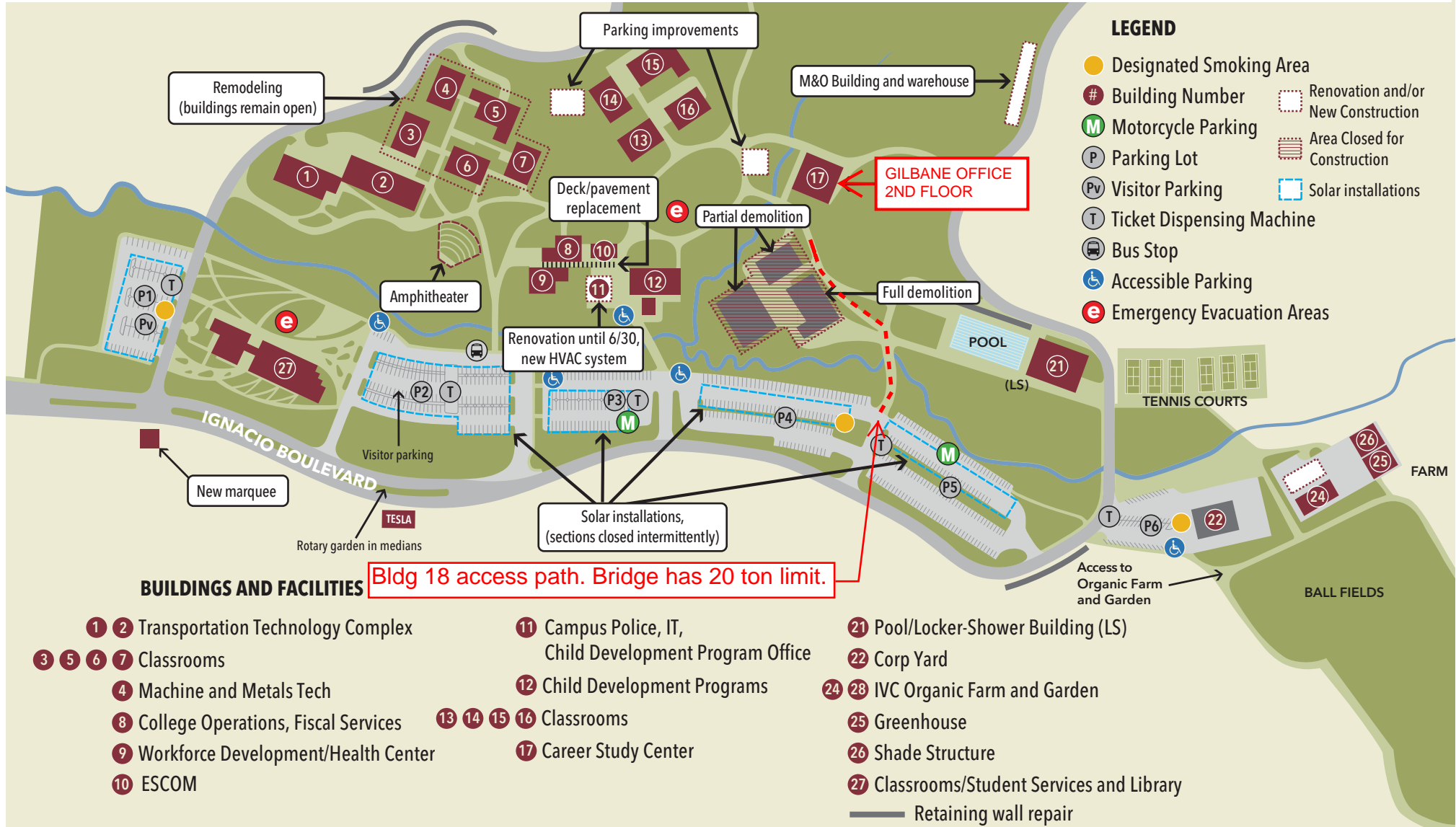

Last updated: March, 2017

PARKING

Designated parking available for: motorcycles, and persons with disabilities. Vehicles on campus are subject to parking and traffic regulations. All cars must have a permit which may be purchased from the parking ticket dispensers located in parking lots. Parking permits are required at all times, except Sundays and school holidays.

POLICE PHONE NUMBERS

Emergency: 911
Urgent: 415.485.9696
IVC Police Business: 415.883.3179